



THE AIR HEATER OF CHOICE FOR TRUCKS



ULTRA-QUIET AIR HEATER WITH ADVANCED DRIVER CONTROL PANEL

Proheat Air is the new standard for heavy-duty truck air heaters, quietly delivering constant and reliable heat in cold weather environments. Available in 2 and 4 kW models, its high-efficiency design reduces overall vehicle emissions and engine wear by eliminating the need to idle the engine to heat the sleeper cab. Proheat Air saves fuel costs for fleets and operators while helping drivers comply with local idling restrictions.

A digital remote panel provides comprehensive and precise control of Proheat Air from anywhere inside the truck cab.

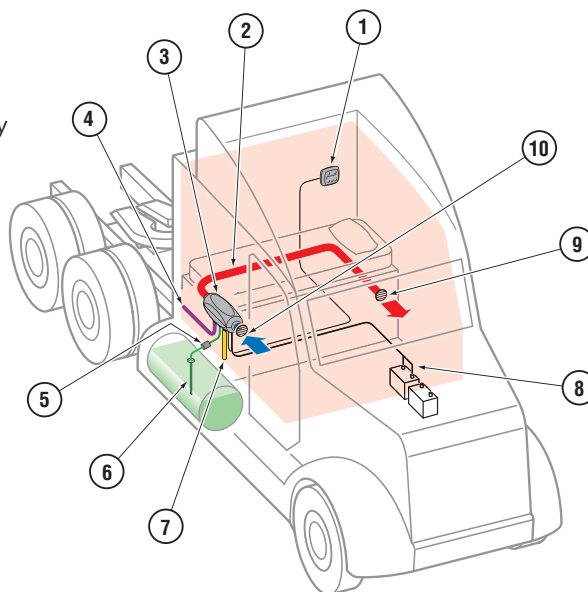

- | | |
|------------------------------|-------------------------|
| 1 Driver Control Panel (DCP) | 6 Fuel Pick-Up |
| 2 Ducting | 7 Combustion Air Intake |
| 3 Heater | 8 Electrical Connection |
| 4 Exhaust | 9 Heated Air |
| 5 Electric Fuel Pump | 10 Air Intake |

AT A GLANCE

HEATER FEATURES

- 2kW (A2) and 4kW (A4) models available
- Built-in temperature sensor for safety and control
- Ultra-quiet operation
- Two year warranty





SPECIFICATIONS

PROHEAT AIR A2 (2kW)

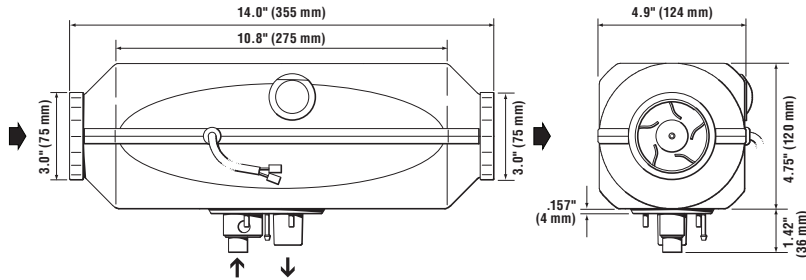

PROHEAT AIR A4 (4kW)

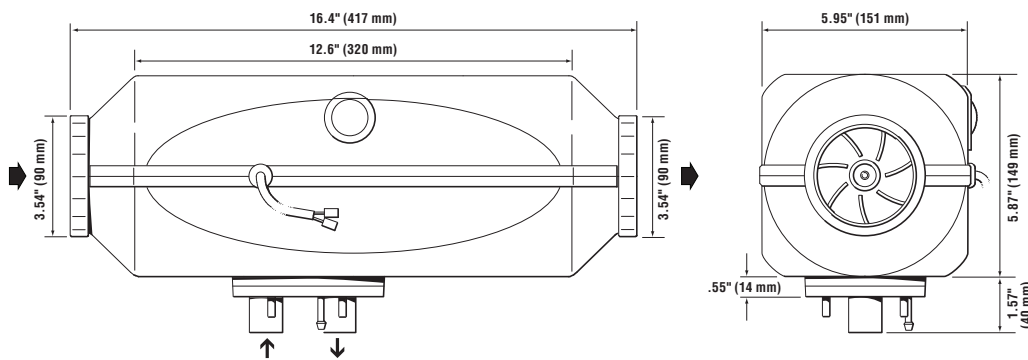

OPTIONAL COMPONENTS

- Temperature sensor

➔ CABIN AIR ⬆️ COMBUSTION AIR

MODEL	A2 (12V)	A2 (24V)	A4 (12V)	A4 (24V)
RATING	2 kW (6,800 BTU)	2 kW (6,800 BTU)	4 kW (13,600 BTU)	4 kW (13,600 BTU)
OPERATING VOLTAGE RANGE	10.5 – 15 VDC	21 – 30 VDC	10.5 – 15 VDC	21 – 30 VDC
POWER CONSUMPTION				
Stand-By	0.4 W	0.4 W	0.4 W	0.4 W
Ignition	130 W	130 W	145 W	145 W
Maximum Heat	25 W	25 W	60 W	60 W
FUEL CONSUMPTION	.03-.06 g/hr (0.1-0.22 L/hr)	.03-.06 g/hr (0.1-0.22 L/hr)	.06-.12 g/hr (0.21-0.46 L/hr)	.06-.12 g/hr (0.21-0.46 L/hr)
FUEL TYPES	ULSD, Diesel #1, Diesel #2, Arctic, B5 Bio-diesel			
OPERATING TEMPERATURE RANGE	Ventilation Mode: - 40°F to 149°F (- 40°C to 65°C) Heating Mode: - 40°F to 104°F (- 40°C to 40°C)			
AIRFLOW (Maximum)	41 CFM (70 m ³ /hr)		65 CFM (110 m ³ /hr)	
WEIGHT	7.7 lb (3.5 kg)	7.7 lb (3.5 kg)	11.2 lb (5.1 kg)	11.2 lb (5.1 kg)
DIMENSIONS (L x W x H)	14 x 4.75 x 6.14 inches (355 x 120 x 156 mm)		16.4 x 6.1 x 7.4 inches (417 x 154 x 189 mm)	
WARRANTY	Two years parts and labor			

PROHEAT AIR A2/A4 PACKAGE CONTENTS

Description	Qty.
Heater	1
Driver Control Panel (DCP)	1
Fuses	2
Fuel Pump	1
Fuel Pump Mounting Hardware	1
Fuel Pickup Pipe	1
Fuel Line	6
Clamps	8
Air Intake Silencer	1
Exhaust Pipe	1
Exhaust Pipe Mounting Hardware	1
Cable Harnesses	4
Mounting Plate	1
Hot Air Duct, 30"	1
Operator's Manual	1
Warranty Registration	1



Please Note: Specifications are subject to change without notice.

Proheat is registered trademark of Marine Canada Acquisition Inc. and its subsidiary companies.

